

SPECIFICATION

1. SCOPE

This specification is applied to the piezo-element.

2. SPECIFICATION (at 25 °C)

- 2.1 Resonant Frequency : 4.0 ± 0.5 KHz
- 2.2 Resonant Resistance : 100 max
- 2.3 Capacitance : 160000 pF $\pm 30\%$ at 100Hz
- 2.4 Input Voltage : 30 Vp-p max
- 2.5 Operating Temperature : -20 ~ +50
- 2.6 Storage Temperature : -20 ~ +60

3. DIMENSION as per figure

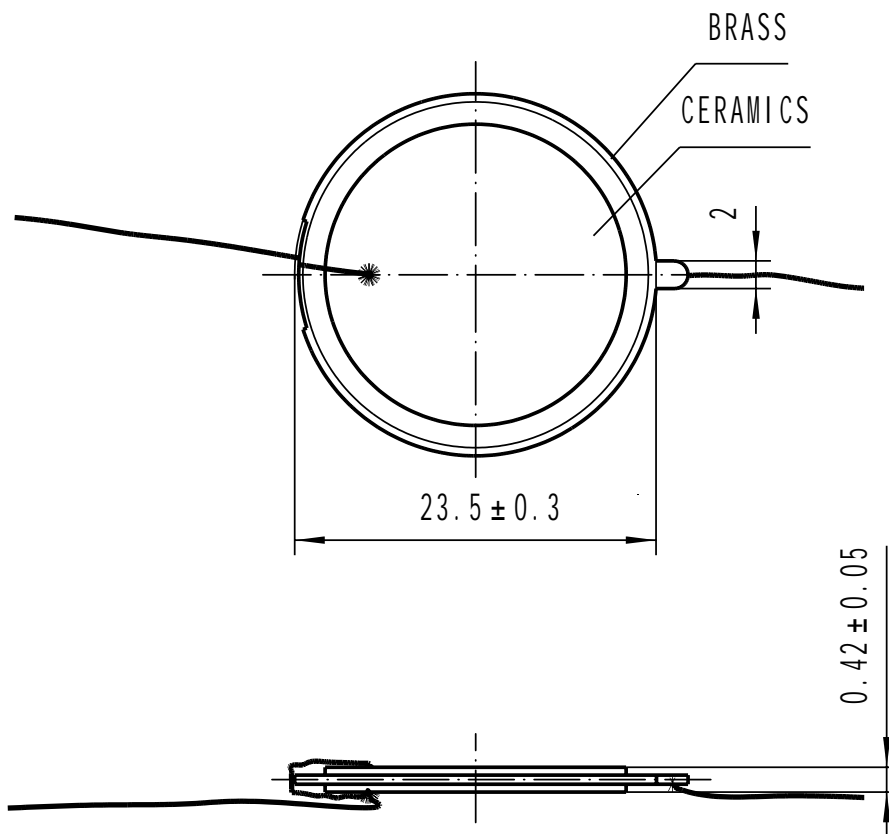

TOLERANCES UNLESS NOTED OTHERWISE .X ± .XX ± .XXX ± 90° FORMED +2° ANGLES -1°		SIGN	DATE	KEPO MODEL NO.	CUSTOMER			
	PREP.		01.08.23	HFT-23.5T-4.0ASL	CUSTOMER NO.			
	ENG.				DWG NO.			
	PROJ.			KP3.840.822	REV	1.1	SHEET	
	CONTRACT NO.				UNIT:	mm	SCALE	
FIRST ANGLE PROJECTION			AGENCY APPROVAL		KEPO CO. LTD. TEL: (+86)574-88370330 FAX: (+86)574-88370329			

